

Alliance Air Dryer Replacement Cartridge



Cleansing your brake system from moisture and contamination, the high quality Alliance Air Dryer Cartridge offers you the safety and confidence you need to keep your truck on the road.

GENERAL PRODUCT INFORMATION

The Alliance air dryer spin-on replacement cartridge is not a will-fitted or re-engineered product. It uses long-life desiccants and is manufactured with OE components following OE specifications. Alliance air dryer cartridges remove 96% of the moisture and contaminants from the air brake system ensuring the system's effectiveness. This product is new; it has not been remanufactured.

PART NUMBER CHART

Alliance Part Number	Description	Application
ABP/N10G-R950011	Air Dryer Cartridge	Spin On

PRODUCT AVAILABILITY

To locate your nearest dealer, please visit www.freightliner.com.

WARRANTY

Alliance air dryer cartridges are subject to consumption during their normal service life and are routinely replaced during normal maintenance services, and therefore are not covered under aftermarket parts warranty.

ADDITIONAL INFORMATION

To learn more about Alliance parts, please visit www.alliancebrandparts.com.

FEATURES & BENEFITS

- 100% greater water absorption
- Extended desiccant cartridge life
- Improved desiccant crust strength
- Significantly increased tolerance of oil contamination
- The spin-on cartridge allows for convenience, reduced downtime, and easy replacement.
- The compact size allows for effective installation in cramped places.
- It's lightweight, so more freight can be carried.
- It prevents contamination, moisture and corrosion in the system.

RELATED BUYS

- Air Brake Control Valves
- Air Compressors
- Electronic Leveling Valves
- D2-Governor
- Hydraulic ABS
- Mechanical Leveling Valves
- Replacement Cartridges
- ABS Components

FREQUENTLY ASKED QUESTIONS

Is the cartridge only important during winter operation?

Answer: No. Air in an unprotected system is always 100% saturated with water vapor. That means that even a one-degree drop in temperature will cause condensation to occur in the system's valves, lines and reservoirs.

What is the function of an air dryer cartridge?

Answer: It protects the vehicle's system by drying moisture-laden air before it passes through air reservoirs and into the brake system.

CROSS-REFERENCE INFORMATION

PART NUMBERS

Alliance	Arvin Meritor	Bendix	Haldex
ABP/N10G-R950011	TDA/R950011 TDA/R109994	BW/BR950011 BW/5008414 BW/109994	HDX/109994K

Alliance Cast Brake Drums by ConMet

The Alliance brake drum product line includes some of the industry's fastest moving drums.



ALLIANCE CAST BRAKE DRUMS – SELECTION GUIDE

Alliance Part Number	Brake Size	Overall Depth	Brake Surface Width	Pilot	Bolt Circle	Bolt Hole Number	Bolt Hole Size	Flange Thickness	Weight	GAWR
ABP/N42A10009830	16.5 X 7	10.56	7.48	8.78	11.25	10	1.00	0.53	112	27,000
ABP/N42A10009920	15 X 4	9.18	4.54	8.78	11.25	10	1.28	0.5	80	14,000
ABP/N42A107193	16.5 X 6	9.74	6.40	8.78	11.25	10	1.28	0.63	109	23,000
ABP/N42A107453	16.5 X 5	9.37	5.31	8.78	11.25	10	1.28	0.5	94	14,700
ABP/N42A107507	15 X 4	8.79	4.66	8.78	11.25	10	1.28	0.5	71	14,000
ABP/N42A107637	16.5 X 8	11.06	8.48	8.78	11.25	10	1.00	0.53	119	26,000
ABP/N42A107638	16.5 X 8.625	11.37	9.00	8.78	11.25	10	1.00	0.62	124	26,000
ABP/N42A107861	15 X 5	9.33	5.30	9.00	275mm	8	1.03	0.5	82	14,000
ABP/N42A107862	15 X 5	9.33	5.30	8.78	11.25	10	1.28	0.5	82	14,000
ABP/N42A107863	15 X 5/6	10.28	7.02	8.78	11.25	10	1.00	0.5	95	12,000
ABP/N42A107864	15 X 5/6	10.28	7.02	9.00	275mm	8	1.00	0.5	92	12,000
ABP/N42A107865	15 X 8.625	11.9	9.21	9.00	275mm	8	1.00	0.5	109	17,000
ABP/N42A107866	15 X 8.625	11.9	9.21	8.78	11.25	10	1.00	0.5	109	17,000
ABP/N42A107875	16.5 X 7	10.56	7.48	9.00	275mm	8	1.00	0.53	112	27,000
ABP/N42A107885	16.5 X 7	10.3	7.28	8.78	11.25	10	1.00	0.53	110	27,000
ABP/N42A107902	15 X 4	9.18	4.54	9.00	275mm	8	1.00	0.5	80	14,000
ABP/N42A107904	16.5 x 7	10.56	7.48	9.00	11.25	10	0.81	0.53	112	27,000

FEATURES & BENEFITS

- Alliance brake drums are cast iron, machined balanced and FMVSS approved.
- Tru-Turn technology on **ABP/N42A10009830** and **ABP/N42A10009920**.

PRODUCT AVAILABILITY

To locate your nearest dealer, please visit www.freightliner.com.

TOP SELLERS

ABP/N42A10009830 **ABP/N42A107866**
ABP/N42A10009920 **ABP/N42A107193**
ABP/N42A107507 **ABP/N42A107638**
ABP/N42A107885

WARRANTY

Alliance Parts are backed by a one-year unlimited mile warranty, with coverage available throughout North America.

ALLIANCE BRAKE DRUM CROSS REFERENCE

Webb Crossover		Gunito Crossover		Meritor Crossover	
Webb Part Number	Alliance Part Number	Gunito Part Number	Alliance Part Number	Meritor Part Number	Alliance Part Number
61528B	ABP/N42A10009830	2769X	ABP/N42A107904	85123399002	ABP/N42A107193
61958B	ABP/N42A107864	3141BX	ABP/N42A107875	85122550002	ABP/N42A107904
61992F	ABP/N42A107866	3141X	ABP/N42A107904	85123207002	ABP/N42A10009830
61999F	ABP/N42A107865	3402X	ABP/N42A107885	85123409002	ABP/N42A107875
62671F	ABP/N42A107193	3600AX	ABP/N42A10009830	85123465002	ABP/N42A107863
65543B	ABP/N42A107902	3687X	ABP/N42A107193	85123570002	ABP/N42A107637
65554B	ABP/N42A107862	3721AX	ABP/N42A107507	85123254002	ABP/N42A107507
66800B	ABP/N42A107637	3726X	ABP/N42A107164	85123365002	ABP/N42A107885
66854F	ABP/N42A107638	3741X	ABP/N42A107902		
66864F	ABP/N42A107150	3744AX	ABP/N42A107865		
66873F	ABP/N42A107885	3744X	ABP/N42A107866		
66875F	ABP/N42A107875	3753AX	ABP/N42A107864		
66895B	ABP/N42A107904	3753X	ABP/N42A107863		
61998B	ABP/N42A107865	3758X	ABP/N42A107453		
65545B	ABP/N42A10009920	3774AX	ABP/N42A107861		
		3774X	ABP/N42A107862		
		3807X	ABP/N42A107638		
		3782X	ABP/N42A107637		
		3800X	ABP/N42A10009920		

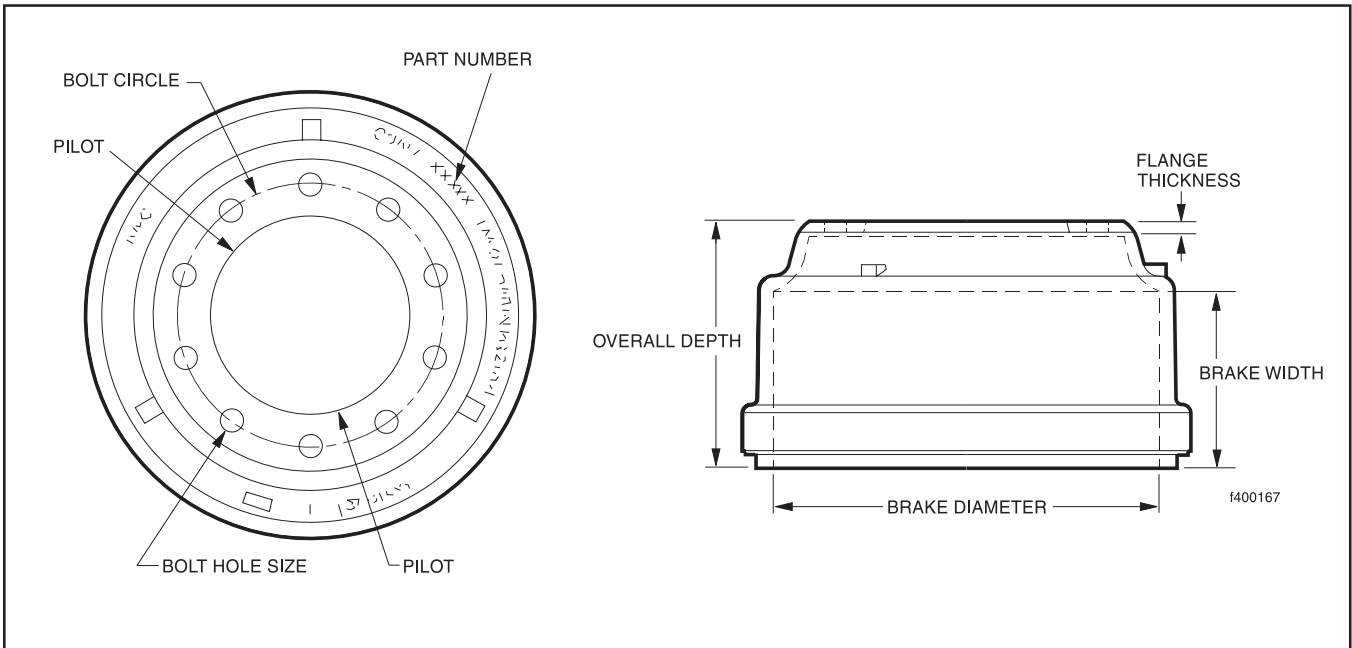



Alliance Remanufactured Air Compressors



Efficient, higher capacity and reliable compressors from Alliance to meet stricter braking requirements and other supported air operated accessories.

GENERAL PRODUCT INFORMATION

The air compressor is the source of energy for the air brake system. It is driven by the vehicle's engine, either by belt or the drive gear.

PART NUMBER CHART

Alliance Part Number	Description	Application
ABP/RC10-5004082	Air Compressor	13CFM TF550 Adaptorless
ABP/RC10-5004083	Air Compressor	16CFM TF750 Adaptorless
ABP/RC10-5010823	Air Compressor	16CFM BA921 (EGR Application)
ABP/RC10-65672	Air Compressor	13CFM TF550 Adaptor
ABP/RC10-65671	Air Compressor	16.5CFM TF750 Adaptor

COMPETITIVE CROSS-REFERENCE CHART

PART NUMBERS

Alliance	Detroit Diesel	Bendix	Bendix Reman	Haldex
ABP/RC10-5004082	DDE/R23522122	BW/5004082	BW/R5004188	HDX/109429X
ABP/RC10-5004083	DDE/R23522123	BW/5004083	BW/R5004187	HDX/109430X
ABP/RC10-5010823	DDE/R23532823	BW/5010823	N/A	HDX/5010824X
ABP/RC10-65672	DDE/R23505234	BW/65672	BW/R107622	HDX/107622X
ABP/RC10-65671	DDE/R23505235	BW/65671	BW/R107623	N/A

PRODUCT AVAILABILITY

To locate your nearest dealer, please visit www.freightliner.com.

WARRANTY

Alliance Parts are backed by a one-year unlimited mile warranty, with coverage available throughout North America.

FOCUS ON QUALITY

- Remanufactured by Master, Fully-Trained, Technicians,
- Using State-of-the-Art Cellular Manufacturing Process,
- In ISO 9001 Certified Facilities,
- With Dedicated Assembly and Quality Assurance Stations,
- Under a Controlled Manufacturing Process.

ADDITIONAL INFORMATION

To learn more about Alliance parts, please visit www.alliancebrandparts.com.

FEATURES & BENEFITS

- 100% replacement of pistons
- 100% replacement of gaskets and bearings
- 100% size inspection of all critical components
- 100% pressure test of cooling system
- 100% computer controlled testing of finished product with test data retention
- Superior surface finish from hone and brush procedure
- No-hassle core criteria



Alliance Remanufactured Air Dryer Cartridge



The Alliance AD9 remanufactured replacement air dryer provides the same high quality brake system protection users have depended on since the system was new, and can be used as a replacement element for standard and extended purge AD9 air dryers.

GENERAL PRODUCT INFORMATION

Air dryers are in line filters between the air compressor and storage reservoirs that remove both liquid and vapor from compressor discharge air before it reaches the reservoir, resulting in only clean dry air being supplied to the air system. The recommended replacement cycle is every two years during normal service.

HIGH MOVERS The AD9 model element is the top selling Bendix air dryer cartridge.

Alliance Part Number	Description	Application
ABP/R42B-107794X	Alliance AD9 remanufactured replacement air dryer desiccant cartridge	Replacement element for standard and extended purge AD9 air dryers

COMPETITIVE CROSSOVER

The ABP/R42B-107794X is a service replacement for the following part numbers:

BW/R107794	Remanufactured Bendix AD9 Air Dryer Cartridge
BW/107796	New Bendix AD9 Air Dryer Cartridge
HXD/107794X	Remanufactured Haldex AD9 Air Dryer Cartridge

RELATED SERVICE ITEMS

D2-Governor

- TDA/RKN18530 – D2-Governor 1 each
- TDA/RKN18536 – D2-Governor 6 Pack

Correct operation of the D2-Governor is essential for controlling proper air dryer purge, necessary for regeneration. Proper regeneration significantly extends dryer cartridge life and assures optimum performance.

PRODUCT AVAILABILITY

To locate your nearest dealer, please visit www.freightliner.com.

WARRANTY

Alliance Parts are backed by a one-year unlimited mile warranty, with coverage available throughout North America.

FREQUENTLY ASKED QUESTIONS

Question Is the same cartridge kit used for standard and extended purge dryers?
Response Yes.

Question Is the dryer cartridge only important during winter operation?
Response No, air in an unprotected brake system **is always** 100% saturated with water vapor. This means that even a one-degree drop in air temperature will cause condensation to form in the system's valves, lines, and reservoirs. Winter operations provide opportunity for this moisture to freeze; however, the moisture itself is always damaging to the air system.

Question **Is it difficult to replace the service cartridge element?**
Response No. The service cartridge element is self contained for easy replacement at any Freightliner Group repair facility.

FEATURES & BENEFITS

- Environmentally friendly, the recycling of the desiccant cartridge prevents material that is oil soaked from being disposed of in the environment.
- This product is equivalent in performance and quality when compared to the genuine AD9 remanufactured air dryer cartridge.
- The Alliance air dryer cartridge is brought to you at an attractive price that brings you maintenance cost savings reducing your overall cost per mile of operation.

CORE INFORMATION

Alliance AD9 remanufactured air dryers are sold remanufactured exchange.

For full core credit, your core will be visually inspected to determine that the canister is not bent or dented, and to assure threads are not crossed-threaded or stripped.

ADDITIONAL INFORMATION

To learn more about Alliance parts, please visit www.alliancebrandparts.com.



Alliance Remanufactured Carriers

Alliance remanufactured carriers offer a combination of OEM quality and a new level of value.



PART NUMBERS

ABP/R35-QD100-342	ABP/R35-QR100-373	ABP/R35-RD23160-456	ABP/R35-RR20145-390
ABP/R35-QD100-355	ABP/R35-QR100-390	ABP/R35-RDL20145-433	ABP/R35-RR20145-411
ABP/R35-QD100-370	ABP/R35-QR100-410	ABP/R35-RDL20145-456	ABP/R35-RR20145-433
ABP/R35-QD100-373	ABP/R35-QR100-411	ABP/R35-RDL20145-463	ABP/R35-RR20145-456
ABP/R35-QD100-390	ABP/R35-QR100-433	ABP/R35-RDL20145-488	ABP/R35-RR20145-463
ABP/R35-QD100-410	ABP/R35-QR100-463	ABP/R35-RP20145-373	ABP/R35-RR20145-488
ABP/R35-QD100-411	ABP/R35-QR100-529	ABP/R35-RPL20145-373	ABP/R35-RR23160-410
ABP/R35-QD100-433	ABP/R35-RD20145-279	ABP/R35-RPL20145-390	ABP/R35-RR23160-456
ABP/R35-QD100-463	ABP/R35-RD20145-293	ABP/R35-RPL20145-411	ABP/R35-RRL20145-373
ABP/R35-QD100-529	ABP/R35-RD20145-307	ABP/R35-RPL20145-433	ABP/R35-RRL20145-390
ABP/R35-QHD-355	ABP/R35-RD20145-321	ABP/R35-RPL20145-463	ABP/R35-RRL20145-411
ABP/R35-QHD-370	ABP/R35-RD20145-342	ABP/R35-RPL23160-410	ABP/R35-RRL20145-433
ABP/R35-QHD-411	ABP/R35-RD20145-358	ABP/R35-RPL23160-430	ABP/R35-RRL20145-456
ABP/R35-QHD-529	ABP/R35-RD20145-373	ABP/R35-RPL23160-456	ABP/R35-RRL20145-463
ABP/R35-QHR-355	ABP/R35-RD20145-390	ABP/R35-RR20145-279	ABP/R35-RRL20145-488
ABP/R35-QHR-370	ABP/R35-RD20145-411	ABP/R35-RR20145-293	ABP/R35-RRL23160-410
ABP/R35-QHR-411	ABP/R35-RD20145-433	ABP/R35-RR20145-307	ABP/R35-RRL23160-430
ABP/R35-QHR-529	ABP/R35-RD20145-456	ABP/R35-RR20145-321	ABP/R35-RRL23160-456
ABP/R35-QR100-342	ABP/R35-RD20145-463	ABP/R35-RR20145-342	ABP/R35-RS17220-488-680
ABP/R35-QR100-355	ABP/R35-RD20145-488	ABP/R35-RR20145-358	ABP/R35-RS17220-614-857
ABP/R35-QR100-370	ABP/R35-RD23160-410	ABP/R35-RR20145-373	

The Alliance carrier part number structure is similar to the Meritor format. Simply replace the TDA prefix with ABP/R35. Alliance carrier part numbers do not require an R suffix, as is common with Meritor part numbers. For example:

<u>Alliance Part Number</u>	<u>Meritor Part Number</u>
-----------------------------	----------------------------

ABP/R35-QD100-390	TDA/QD100 -390R
-------------------	-----------------

Note: For purpose of clarity, spaces within part numbers are designated with a hyphen (-), and the part number prefix is followed by a slash (/)

FEATURES & BENEFITS

- Manufactured in OE facilities using original equipment processes.
 - To assure superior quality.
- Manufactured to approved original equipment specifications.
- Upgraded to include the latest engineering technology.
- Seals and bearings are replaced with new OEM level product.
- Internal components are thoroughly inspected using engineering approved specifications.
- Internal gearing is inspected using master gearing nests to check for wear.
- All gearing is magnafluxed to check for hidden cracks and defects.
- All units must pass a loaded dyno test which tests for proper ratio, load capability and noise.

TOP SELLERS

- | | |
|----------------------------|----------------------------|
| ABP/R35-RD20145-390 | ABP/R35-RD20145-411 |
| ABP/R35-RD20145-373 | ABP/R35-QR100-355 |
| ABP/R35-QD100-355 | ABP/R35-QD100-390 |
| ABP/R35-QD100-373 | ABP/R35-QR100-373 |
| ABP/R35-QD100-410 | ABP/R35-QR100-410 |
| ABP/R35-RR20145-390 | ABP/R35-RD20145-358 |

CONSIDER THE FOLLOWING WHEN PURCHASING AN ALLIANCE CARRIER:

- | | |
|--------------------------------|------------------------|
| • End yokes | • Axle shafts |
| • Seal and bearing kits | • Axle housings |

PRODUCT AVAILABILITY

To locate your nearest dealer, please visit www.freightliner.com.

WARRANTY

Alliance Parts are backed by a one-year unlimited mile warranty, with coverage available throughout North America.

WHEN YOU NEED MORE INFORMATION...

The following literature is available to you at your local dealer.

Catalog Number	Description
PB-94184 (8/01)	Carrier Quick Reference Guide

CORE INFORMATION

Return cores to your local dealer.

Alliance Spring Brakes

You're assured of the highest quality spring brake when you purchase Alliance spring brakes.

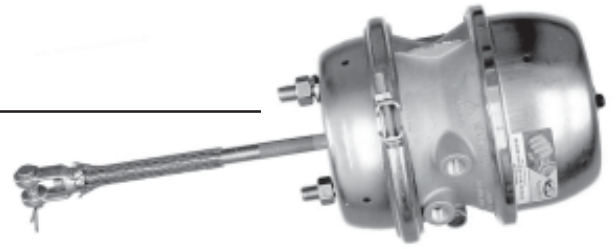

GENERAL PRODUCT INFORMATION

- Alliance spring brakes are designed to provide years of safe, dependable service for parking or emergency braking applications. These spring brakes and service chambers feature rugged construction, using heavy gauge steel brake housings and steel components throughout.
- Alliance spring brakes are manufactured by an ISO9001: 2000 certified company that manufactures nearly all of the brake components in house. They stamp, form and assemble our housings and then perform extensive testing to ensure the brakes will perform as designed.
- The leading cause of premature spring brake failure is mis-alignment of the power spring or push rod. Alliance spring brakes are designed to solve these common problems, helping to ensure delivery of a long service life without maintenance problems.
- Alliance spring brakes will help reduce maintenance costs by providing greater corrosion resistance and eliminating component failure.

WARRANTY

Alliance Parts are backed by a one-year unlimited mile warranty, with coverage available throughout North America.

PRODUCT AVAILABILITY

To locate your nearest dealer, please visit www.freightliner.com.

FEATURES & BENEFITS

- **Chrome Silicon Steel Main Spring**—Epoxy coated for corrosion protection. A unique shot peening process is applied which dramatically extends the life of the spring.
- **Guided Spring Pressure Plate**—Keeps pressure plate centered preventing side forces which cause diaphragm sidewall and seal wear.
- **Mechanical Sure Crimp Seal**—A special crimping method ensures a no-guess diaphragm seal and allows a low profile without clamp interference.
- **Chrome Plated Internal Push Rod**—Chrome plated steel ground to just the right finish—Rough Machine Surface (32RMS)—to retain lubrication and prevent premature seal wear. Hard chrome for wear resistance and corrosion protection.
- **Heavy Duty Premium Diaphragms**—Synthetic blended rubber for superior resistance against abrasion and fatigue cracking. Tested to 1,000,000 cycles.
- **Music Wire Return Springs**—Made from pre-galvanized wire for maximum corrosion protection. Low stress barrel configuration.
- **Heavy 10-Gauge Non-pressure Housing**—Designed for bracket contact at the crucial outer edges. Mounting studs are reinforced to prevent pull out.
- **Friction Welded Push Rod**—Provides a total attachment to the plate preventing the rod from breaking loose.

PART NUMBER REFERENCE CHART			
Part Number	Description	Part Number	Description
PIGGYBACKS		SERVICE CHAMBERS (CONT)	
ABP/N42A-12024PD	2024 Boxed	ABP/N42A-24SCND	24" Boxed-No Clevis
ABP/N42A-12424PD	2424 Boxed	ABP/N42A-24SC3D	24" 3" Stroke-Boxed-With Clevis
ABP/N42A-12430PD	2430 Boxed	ABP/N42A-24SC3ND	24" 3" Stroke-Boxed-No Clevis
ABP/N42A-13030PD	3030 Boxed	ABP/N42A-30SCD	30" Boxed-With Clevis
ABP/N42A-13036PD	3036 Boxed	ABP/N42A-30SCND	30" Boxed-No Clevis
ABP/N42A-13636PD	3636 Boxed	ABP/N42A-30SC3D	30" 3" Stroke-Boxed-With Clevis
ABP/N42A-24PBKD	24 Kit	ABP/N42A-30SC3ND	30" 3" Stroke-Boxed-No Clevis
ABP/N42A-30PBKD	30 Kit	ABP/N42A-36SCD	36" Boxed-With Clevis
SPRING BRAKES		COMPONENT PARTS	
ABP/N42A-12024CD	2024 Combo-Boxed-With Clevis	ABP/N42A-10026AD	1/2" Clevis Assembly
ABP/N42A-42024CD	2024 Combo-Boxed-No Clevis	ABP/N42A-10026BD	5/8" Clevis Assembly
ABP/N42A-12424CD	2424 Combo-Boxed-With Clevis	ABP/N42A-24013AD	24" Service Brake Push Rod
ABP/N42A-42424CD	2424 Combo-Boxed-No Clevis	ABP/N42A-24016AD	24" Nonpressure Housing
ABP/N42A-12430CD	2430 Combo-Boxed-With Clevis	ABP/N42A-24020AD	24" Clamp Assembly
ABP/N42A-42430CD	2430 Combo-Boxed-No Clevis	ABP/N42A-24021AD	24" Steel Pressure Cap
ABP/N42A-12430C3D	2430 Combo-3" Stroke-Boxed-With Clevis	ABP/N42A-30013AD	30" Service Brake Push Rod
ABP/N42A-42430C3D	2430 Combo-3" Stroke-Boxed-No Clevis	ABP/N42A-30016AD	30" Nonpressure Housing
ABP/N42A-13030CD	3030 Combo-Boxed-With Clevis	ABP/N42A-30036AD	30" Nonpressure Housing For 3036 Combo
ABP/N42A-43030CD	3030 Combo-Boxed-No Clevis	ABP/N42A-30020AD	30" Clamp Assembly
ABP/N42A-13030C3D	3030 Combo-3" Stroke-Boxed-With Clevis	ABP/N42A-30021AD	30" Steel Pressure Cap
ABP/N42A-43030C3D	3030 Combo-3" Stroke-Boxed-No Clevis	DIAPHRAGMS	
ABP/N42A-13036CD	3036 Combo-Boxed-With Clevis	ABP/N42A-D09000D	9" Low-Temp Diaphragm
ABP/N42A-43036CD	3036 Combo-Boxed-No Clevis	ABP/N42A-D12000D	12" Low-Temp Diaphragm
ABP/N42A-13636CD	3636 Combo-Boxed-With Clevis	ABP/N42A-D16000D	16" Low-Temp Diaphragm
ABP/N42A-43636CD	3636 Combo-Boxed-No Clevis	ABP/N42A-D20000D	20" Low-Temp Diaphragm
SERVICE CHAMBERS		ABP/N42A-D24000D	24" Low-Temp Diaphragm
ABP/N42A-12SCD	12" Boxed-With Clevis	ABP/N42A-D24002D	24" Long Stroke Low-Temp Diaphragm
ABP/N42A-12SCND	12" Boxed-No Clevis	ABP/N42A-D24003D	24" Low-Temp Diaphragm
ABP/N42A-16SCD	16" Boxed-With Clevis	ABP/N42A-D30000D	30" Low-Temp Diaphragm
ABP/N42A-16SCND	16" Boxed-No Clevis	ABP/N42A-D30003D	30" 3" Stroke Low-Temp Diaphragm
ABP/N42A-20SCD	20" Boxed-With Clevis	ABP/N42A-D36000D	36" 3" Stroke Low-Temp Diaphragm
ABP/N42A-20SCND	20" Boxed-No Clevis		
ABP/N42A-24SCD	24" Boxed-With Clevis		